

### Caractéristiques :

- Robustesse
- Clapet anti-retour
- Vérin double effet
- Facile à utiliser
- Adaptable à tout rotateur

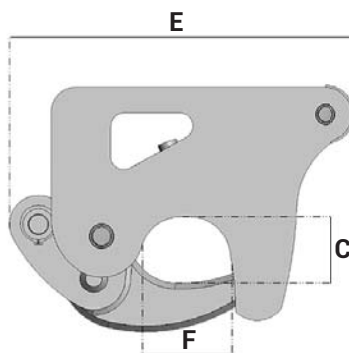
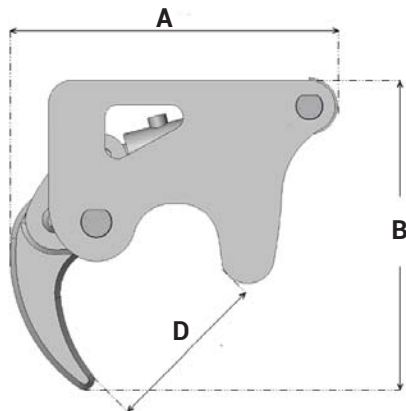

<b>A</b>	418
<b>B</b>	483
<b>C</b>	74
<b>D</b>	215
<b>E</b>	417
<b>F</b>	108

### CARACTERISTIQUES



ARH 30

15

0,3

- Vitesse de fermeture: 2,2 sec
- Vitesse d'ouverture 1,5 sec
- Axe de rotateur: 50(69)/30

