

TIGERGRIP | TIGER CUT 200c

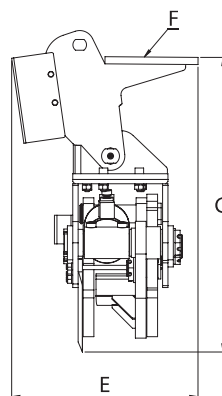

Caractéristiques :

- Usage intensif
- Aciers à haute résistance mécanique (450 HB)
- Vérin haute pression avec double joint de piston

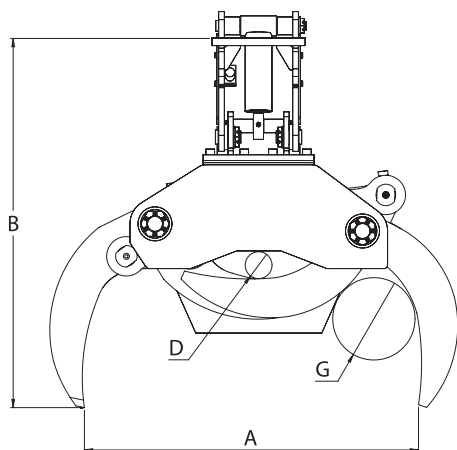

A	1140
B	987
C	826
D	396
E	208
F	769
G	339

CARACTERISTIQUES



TIGER CUT 200c

225

250

50

53

INTERMERCAT

Accessoires de levage et de chargement de haute performance pour le forestier, le transport, le TP et le recyclage.

