

ROTECH / RMR 6-224

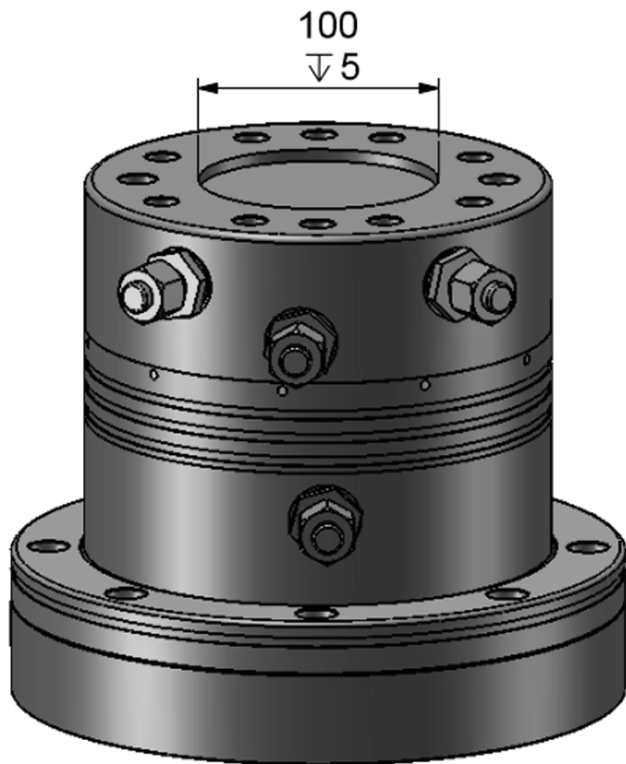

Caractéristiques :

- Haute pression
- Rotation continue
- Couple élevé
- Positionnement optimisé
- Flasque en acier pour une durabilité accrue

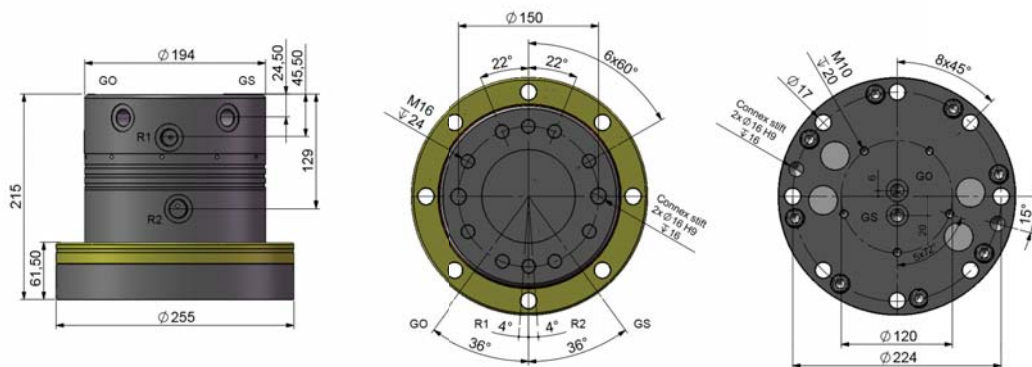

CARACTERISTIQUES



RMR 6-224

61

16

320

22

360°

2800

G1/2

16

7

INTERMERCATO

Accessoires de levage et de chargement de haute performance pour le forestier, le transport, le TP et le recyclage.

