

TIGERGRIP / TG 42 SM-R

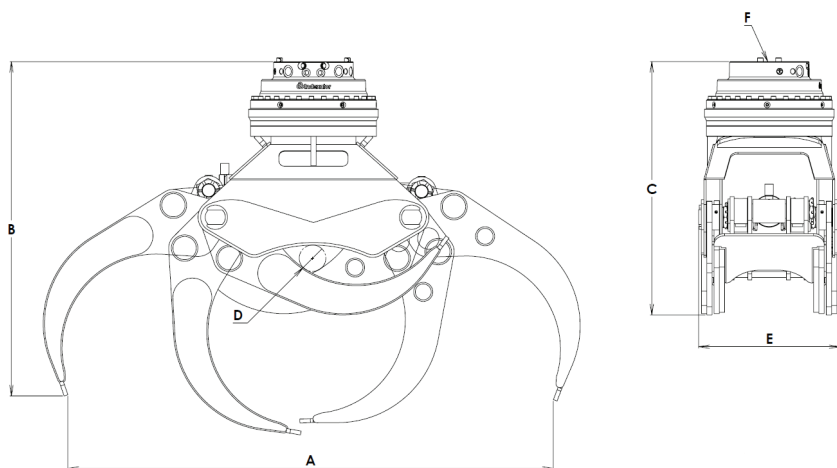

Caractéristiques :

- Usage intensif
- Double barres de guidage
- Capacité à enrouler et dérouler le bois optimisée
- Vérin haute pression avec double joints de piston
- Acier à haute résistance mécanique (400 HB)
- Double structure renforcée pour montage rigide sur pelle
- Complet avec rotateur Indexator XR400



A	1831
B	1265
C	960
D	100
E	540
F	XR400

CARACTERISTIQUES



TG 42 SM-R	721	0,50	300	70	21,8	10	35	25	35			
------------	-----	------	-----	----	------	----	----	----	----	--	--	--

INTERMERCATO

Accessoires de levage et de chargement de haute performance pour le forestier, le transport, le TP et le recyclage.

