

# TIGERGRIP / TG 28

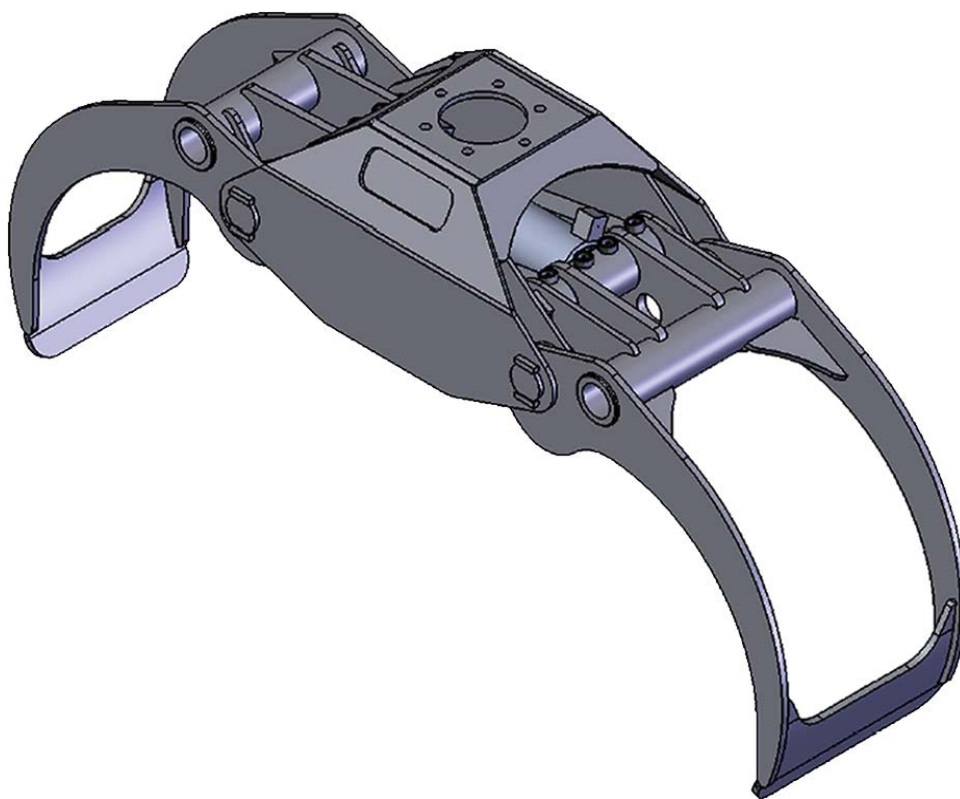

## Caractéristiques :

- Doubles barres de guidage
- Propriété à enrouler et dérouler le bois optimisée
- Vérin haute pression avec double joint de piston
- Acier à haute résistance mécanique (400 HB)

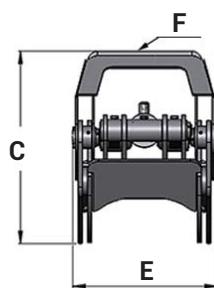
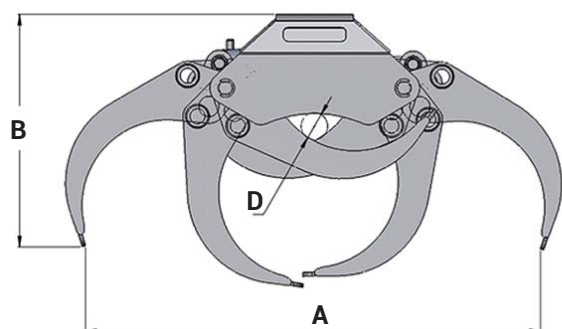

<b>A</b>	1490
<b>B</b>	785
<b>C</b>	530
<b>D</b>	100
<b>E</b>	416
<b>F</b>	173/6

## CARACTERISTIQUES



TG 28

180

0,30

250

60

16,6

8

3

# INTERMERCAT

Accessoires de levage et de  
chargement de haute performance  
pour le forestier, le transport, le TP et  
le recyclage.

